



Precision Color Matching - TP 310



Model No. TP310

Precision Color Matching TP310 is a consistent tool useful for portable and high quality color measurement. It works with color sensor with multiple channels according to international standards. Color Matching TP310 complies with various CIE Standards.

- Adopts accurate camera locating feature
- Illumination locating for user ease of operation
- Software based output of test results
- Auto white and black calibration
- Various Color Sources
- Display of Whiteness, Yellowness and Color Fastness
- Convenient Operation and ergonomic design

The portable color measurement instrument is used to measure the color consistency of various types of products and is designed for many production verticals like plastics, rubbers, paper & Packaging, paint & plating, automotive, textile and many more.

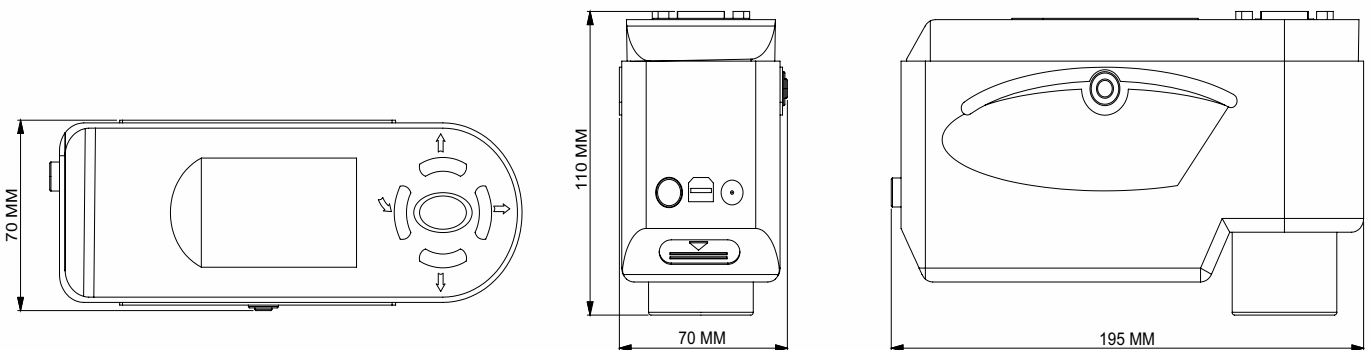

Top View

Front View

Side View

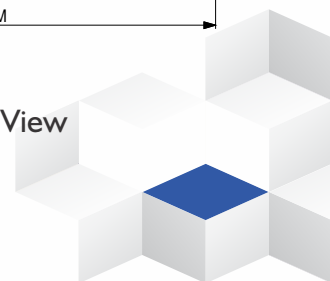



Presto Stantest Pvt. Ltd.

I-42, DLF Industrial Area Phase-1, Delhi Mathura Road, Faridabad 121003, Haryana, India
P : 9210 903 903, +91 129 4272727, 93111 24302 E : info@prestogroup.com



- Faridabad • Sonapat • Kolkata • Mumbai • Pune • Ahmedabad
- Chennai • Bangalore • Hyderabad

www.prestogroup.com

Key Specifications:

Illumination/Observation system	8/d (8° illumination angle/diffuse viewing)
Measuring Aperture	8 mm, 4 mm(Diameter) *Optional: 8 mm (Diameter) extended aperture
Light Sources	D-65, D-50, A (LED Blue light excitation)
Detector	Silicon photoelectric diode
Color Spaces Indices	Yellowness & Whiteness color fastness CIEL*a*b*C*h* CIEL*a*b* CIEXYZ CIERGB CIEL*u*v* CIEL*C*h
Minimum Interval Between measurement	Approx 1.0s
Measuring range	L:0 to 100
Repeatability	Standard deviation within $\Delta E^*ab0.06$ (avg. on 30 measurement with standard white plate.)

Highlights:

Battery	Li-ion battery(Lithium Ion,3200mAh)
Lamp Life	5 yearsapprox..
Display	2.8 Inch@16:9 TFT true color
Storage	Upto 20000 samples and 100 standards
Communication Port	USB
Dimensions	195x70x110mm

* Can test powder and liquid using
(Universal Test Component optional)

Standard Accessory:

- AC Adapter, Li-ion Battery
- Operation Manual
- Software CD
- USB Cable
- White Calibration Cover
- 4mm Measuring Aperture

Optional Accessory:

- Extended Aperture (8mm Diameter), Mini printer, Printer cable, Universal test components, Powder test box
- Other model TP 800 also available on request.

Thank you customers for choosing us as your partners in growth !



*All the above logos are the sole property of their respective owners and are used purely for depiction purposes only.

OUR OTHER PRODUCTS :-

Top Load Tester	Wall Thickness Gauge	Gloss Meter Triangle	Eccentricity Tester	Moisture Analyzer MB 45	Preform Neck Cutter

www.prestogroup.com

